

CLDP500

High Performance Audio Amplifier Module

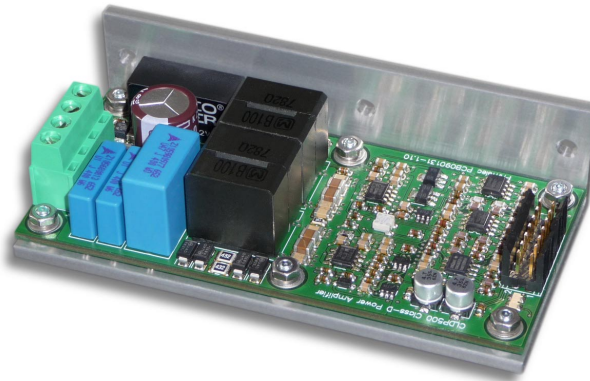

General Description

The CLDP500 is a Class-D amplifier module with 500W high-quality output power over the full audio bandwidth. The high-end performance is achieved by the module's fully differential architecture, using a self-oscillating modulator with dual feedback topology, balanced true FET input stage and full-bridge power stage.

The CLDP500 is intended as a versatile amplifier module to design innovative audio solutions. The module's turn-key approach ensures shortest possible Time-to-Market for the end product.

Two versions of the module are available, differing only in the power supply requirements. The CLDP500-DCDC with on-board DC/DC converter works with a single supply voltage. The lower-cost version CLDP500-AUXV comes without DC/DC converter and requires auxiliary supply voltages for operation (+/-12V).

Both versions have a very compact design and provide excellent sound quality, very low radiated and conducted EMI, various protection circuits, adjustable dead-time, a standby input and outputs for status indication, temperature monitoring and fan driving with temperature regulated speed.

Typical Applications

- Professional high-end audio
- Active speakers and subwoofers
- A/V amplifiers and receivers
- Powerful automotive audio
- DIY-Projects
- Public address systems

Key Specifications

- THD+N = 0.0003% (5W, 8Ω, 1kHz)
- THD+N < 0.03% (500W, 4Ω, 20Hz < f < 20kHz)
- Power bandwidth = 3Hz to 60kHz (+0/-3dB, 4Ω)
- Dynamic range > 120dB
- Overall efficiency = 93% (250W, 8Ω)
- Module size = 100 x 50 x 25mm

Main Features

- Balanced audio input / output with differential true FET input stage and full-bridge power stage
- Single supply operation (CLDP500-DCDC), wide operating voltage range
- Undervoltage, overcurrent and overtemperature protection
- Adjustable dead-time of the power stage to tune for minimal THD or quiescent current
- Pop-free start and stop operation
- Standby input, standby power consumption < 2W
- Output for fan driving with temperature regulated speed (12V / 1W max)
- Outputs for status indication and temperature monitoring
- Customized designs available, contact Primelec for further information

Block Diagrams

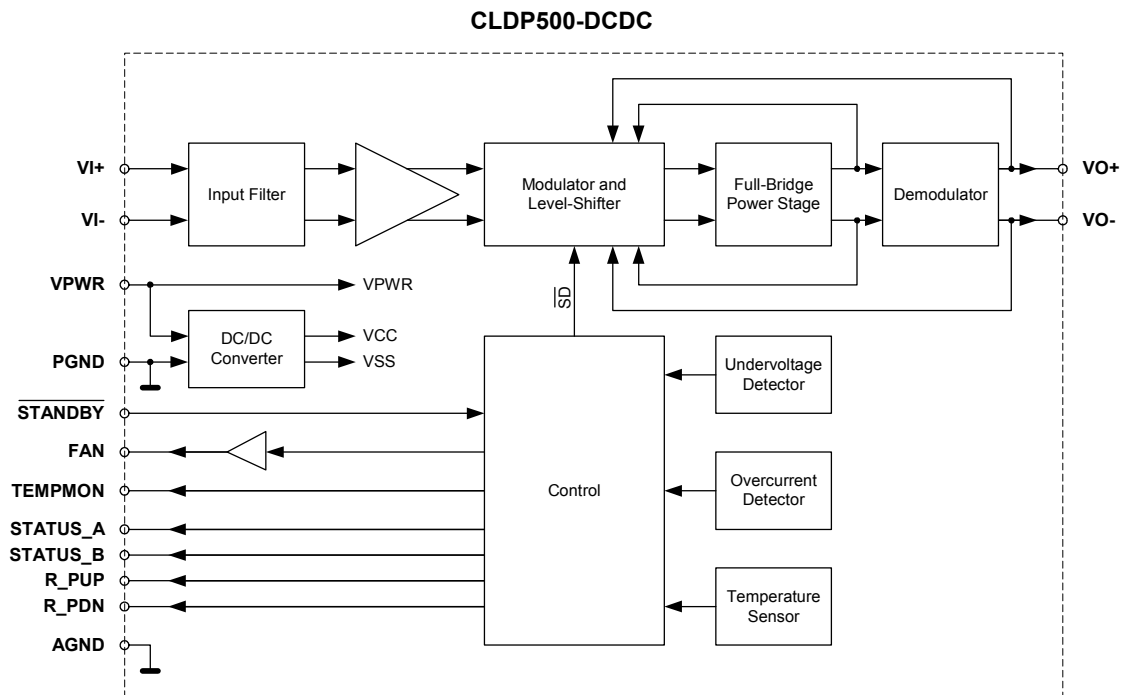

Figure 1: Block diagram of the CLDP500-DCDC (single supply operation)

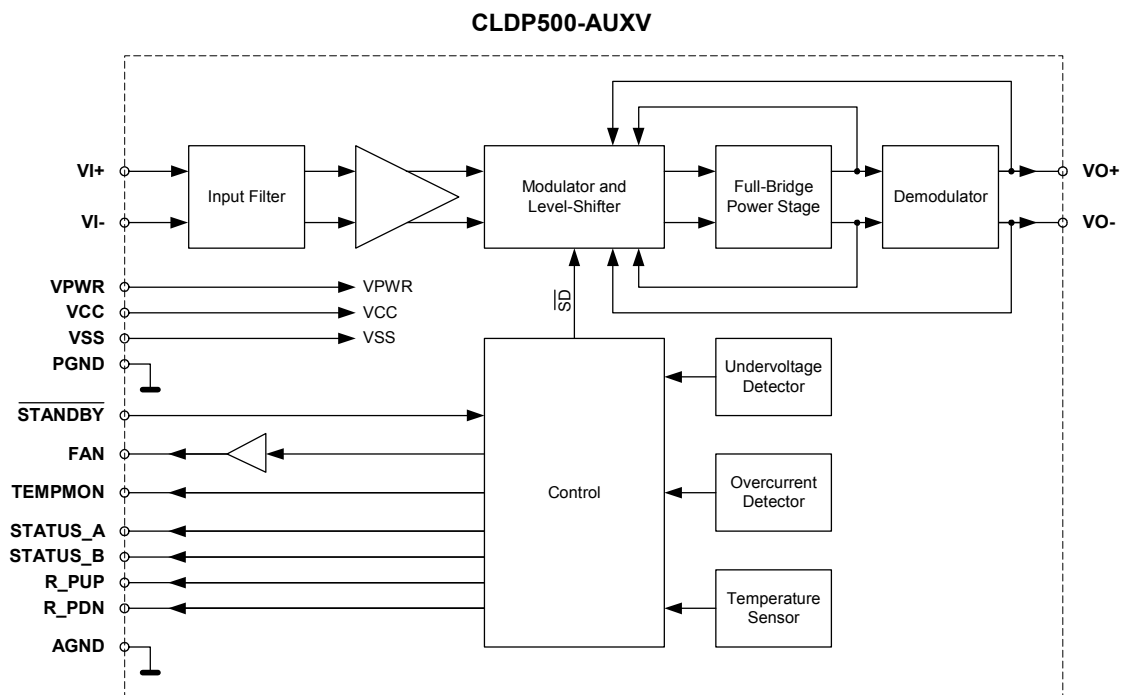

Figure 2: Block diagram of the CLDP500-AUXV (auxiliary supply voltages required)

Connection Diagrams

CLDP500-DCDC

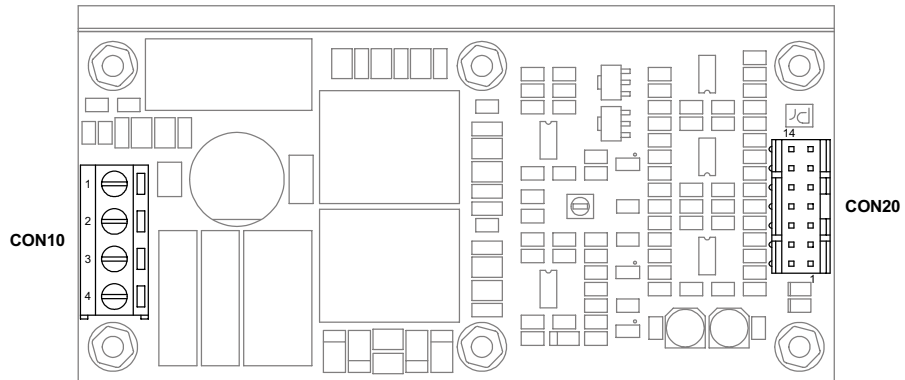

Figure 3: Connection diagram of the CLDP500-DCDC (single supply operation)

CLDP500-AUXV

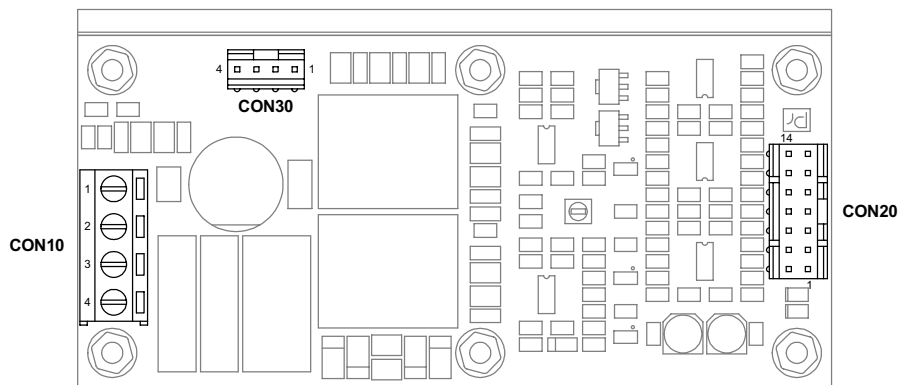

Figure 4: Connection diagram of the CLDP500-AUXV (auxiliary supply voltages required)

Note: The chassis (aluminum mounting bracket) is internal connected to ground via resistor 10k || capacitor 10n

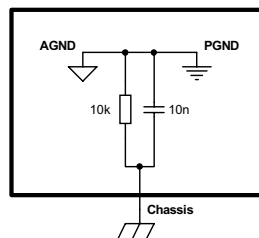

Figure 5: Internal chassis connection (CLDP500-DCDC and CLDP500-AUXV)

Connector Descriptions

CON10 (Power)

Type: Printed circuit terminal block, 4 positions

Specifications: Pitch 5mm, screw connection, conductor cross section 1.5mm² max.

Pinout:

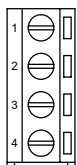

Pin	Signal	Function
1	VPWR	Main supply voltage for the power section
2	PGND	Ground terminal for the power section
3	VO-	Balanced audio power output "cold" (in phase with signal VI-)
4	VO+	Balanced audio power output "hot" (in phase with signal VI+)

CON20 (Low Level Signals)

Type: Rectangular shrouded header, 14 positions, male pins, 2 rows (FCI 69168-114HLF)

Specifications: Pitch 2.54mm, mates with rectangular housing FCI 69176-014LF and housings without polarizing key

Pinout:

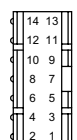

Pin	Signal	Function
1	AGND	Ground terminal for the signal section
2	VI-	Balanced audio signal negative input
3	AGND	Ground terminal for the signal section
4	VI+	Balanced audio signal positive input
5	STANDBY	Standby signal input (active low, internal pull-up to +5V)
6	AGND	Ground terminal for the signal section
7	STATUS_A	Status signal "A" output
8	STATUS_B	Status signal "B" output
9	R_PDN	Passive output for LED connection (internal pull-down resistor to AGND)
10	R_PUP	Passive output for LED connection (internal pull-up resistor to +5V)
11	AGND	Ground terminal for the signal section
12	TEMPMON	Temperature monitor signal output (temperature controlled voltage)
13	AGND	Ground terminal for the signal section
14	FAN	Fan drive positive output (temperature controlled voltage)

CON30 (CLDP500-AUXV only, Auxiliary Supply Voltages)

Type: Rectangular shrouded header, 4 positions, male pins, 1 row (FCI 69167-104HLF)

Specifications: Pitch 2.54mm, mates with rectangular housing FCI 78211-004LF and housings without polarizing key

Pinout:



Pin	Signal	Function
1	VSS	Negative auxiliary supply voltage for the signal section
2	AGND	Ground terminal for the signal section
3	VCC	Positive auxiliary supply voltage for the signal section
4	AGND	Ground terminal for the signal section

Electrical Characteristics

Absolute Maximum Ratings

Stresses above these ratings may cause permanent damage

Symbol	Parameter	Value	Unit
V _{PWR}	Main Supply Voltage	0 to 75	V
V _{CC}	Positive Auxiliary Supply Voltage ^(note 1)	0 to 13	V
V _{SS}	Negative Auxiliary Supply Voltage ^(note 1)	-13 to 0	V
V _{IN}	Input Voltage on Pins VI+ and VI-	(V _{SS}) -0.7 to (V _{CC}) +0.7	V
V _S	Input Voltage on Pin STANDBY	-0.7 to 5.5	V
I _{FAN}	Output Current on Pin FAN	0 to 85	mA
C _L	Pure Capacitive Load between Pins VO+ and VO-	0 to 470	nF
T _C	Case Temperature (Mounting Bracket)	0 to 80	°C
T _A	Ambient Temperature	0 to 60	°C

Electrical Specifications – Amplifier Section

The following specifications apply for T_A = 25°C, T_C = 35°C, V_{PWR} = 72V, f = 1kHz, balanced audio inputs, minimal dead-time (unless otherwise noted)

Symbol	Parameter	Conditions	Min	Typ	Max	Unit
THD+N	Total Harmonic Distortion + Noise, MBW 20kHz	P _O = 5W, Z _L = 8Ω		0.0003	0.0005	%
THD+N	Total Harmonic Distortion + Noise, MBW 20kHz	20Hz < f < 20kHz, P _O = 5W, Z _L = 8Ω		0.0007	0.001	%
THD+N	Total Harmonic Distortion + Noise, MBW 20kHz	20Hz < f < 20kHz, 50mW < P _O < 500W, Z _L = 4Ω		0.03	0.05	%
P _{O_MAX}	Maximum Output Power	THD = 1%, Z _L = 4Ω THD = 1%, Z _L = 8Ω		625 325		W
D	Dynamic Range	A-weighted		120		dB
A _V	Voltage Gain		26.5	27	27.5	dB
f _{ABW}	Frequency Response	20Hz < f < 20kHz, Z _L = 4Ω			±0.5	dB
f _{BWL}	Bandwidth Limitation	P _O = 5W, Z _L = 4Ω, +0 / -3dB	3		60k	Hz
Z _O	Output Impedance	f = 1kHz		25		mΩ
Z _L	Load Impedance		2		∞	Ω
Z _I	Input Impedance	Balanced input		100		kΩ
PSRR	Power Supply Rejection Ratio	Δ V _{PWR} = 2V, 100Hz – 1kHz	65			dB
f _{SW_O}	Offset Switching Frequency	Idle		880		kHz
f _{SW_R}	Switching Frequency Range	Full scale to Idle variation	200		(f _{SW_O})	kHz
V _{OS_CM}	Common Mode Output Offset Voltage	Input terminated		(V _{PWR})/2		V
V _{OS_DIFF}	Differential Mode Output Offset Voltage	Input terminated		±25		mV
V _{PWR}	Main Supply Voltage	Operating voltage range	36.0		74.0	V
V _{CC}	Positive Auxiliary Supply Voltage ^(note 1)	Operating voltage range	11.4	12.0	12.6	V
V _{SS}	Negative Auxiliary Supply Voltage ^(note 1)	Operating voltage range	-12.6	-12.0	-11.4	V
I _{VPWR_SD}	Standby Current CLDP500-DCDC ^(note 2) Standby Current CLDP500-AUXV ^(note 2)	With on-board DC/DC converter V _{CC} = 12.0V, V _{SS} = -12.0V		30	1	mA
I _{VPWR_Q}	Quiescent Current CLDP500-DCDC ^(note 3) Quiescent Current CLDP500-AUXV ^(note 3)	With on-board DC/DC converter V _{CC} = 12.0V, V _{SS} = -12.0V	70 40		200 170	mA
I _{VCC}	Quiescent Current ^(note 1)	V _{CC} = 12.0V, V _{SS} = -12.0V		130		mA
I _{VSS}	Quiescent Current ^(note 1)	V _{CC} = 12.0V, V _{SS} = -12.0V		-40		mA
η	Overall Efficiency (CLDP500-DCDC)	P _O = 250W, Z _L = 8Ω		93		%

Note 1: External auxiliary supply voltages are only required for the CLDP500-AUXV (module without DC/DC converter)

Note 2: Standby is activated by pulling low the standby input and / or by the internal protection circuits

Note 3: Quiescent I_{VPWR_Q} current varies with dead-time setting; reduced dead-time results in lower THD and higher I_{VPWR_Q}

Electrical Characteristics (CONT)

Electrical Specifications – Control Section

The following specifications apply for $T_A = 25^\circ\text{C}$, $V_{CC} = 12.0\text{V}$, $V_{SS} = -12.0\text{V}$ (unless otherwise noted)

Symbol	Parameter	Conditions	Min	Typ	Max	Unit
Standby Input						
V_{S_L}	Low Level Input Voltage				1.3	V
V_{S_H}	High Level Input Voltage		3.7			V
I_{S_PU}	Pull-Up Current	Internal pulled-up to +5V		-100		μA
t_{SPD}	Propagation Delay Time	$V_S \leq V_{S_L}$		10		μs
t_{SD}	Delay Time	$V_S > V_{S_H}$		1		s
Temperature Monitor Output						
$V_{TEMPMON}$	Output Voltage Range	See chart 'Thermal Management Outputs vs. t_{NTC} '	0.0		5.25	V
$Z_{TEMPMON}$	Output Impedance			1		$\text{k}\Omega$
Fan Output						
V_{FAN}	Output Voltage Range	See chart 'Thermal Management Outputs vs. t_{NTC} '	0.0		(V_{CC})	V
Z_{FAN_O}	Output Impedance			5		Ω
Z_{FAN_L}	Load Impedance		140		∞	Ω
Status Outputs						
V_{ST_L}	Low Level Output Voltage	$I_{ST} = 100\mu\text{A}$ $I_{ST} = 8\text{mA}$	0.03 1.76		0.2 2.0	V
V_{ST_H}	High Level Output Voltage	$I_{ST} = -100\mu\text{A}$ $I_{ST} = -8\text{mA}$	4.6 2.8		5.23 3.49	V
Z_{ST}	Output Impedance			220		Ω
t_{STPD}	Propagation Delay Time	Change of operation mode			20	ns
Passive Outputs						
Z_{PDN}	Internal Resistor from Pin R_PDN to AGND			220		Ω
Z_{PUP}	Internal Resistor from Pin R_PUP to +5V			220		Ω
Undervoltage Protection Circuit						
V_{PWR_TH}	Threshold Voltage of V_{PWR}			29.2	32.1	V
V_{CC_TH}	Threshold Voltage of V_{CC}			9.5	10.4	V
V_{SS_TH}	Threshold Voltage of V_{SS}		-11.1	-10.1		V
V_{5V_TH}	Threshold Voltage of internal +5V			4.7		V
t_{VPD}	Propagation Delay Time	$V_x \leq V_{x_TH}$		150		μs
t_{VD}	Delay Time	$V_x > V_{x_TH}$		1		s
Overcurrent Protection Circuit						
I_{C_TH}	Threshold Current			20		A
t_{CPD}	Propagation Delay Time	$I_C \geq I_{C_TH}$		1		μs
t_{CD}	Delay Time	$I_C < I_{C_TH}$		1		s
Overtemperature Protection Circuit						
T_{T_TH}	Threshold Temperature			85		$^\circ\text{C}$
T_{T_REL}	Release Temperature			75		$^\circ\text{C}$
t_{TPD}	Propagation Delay Time	$T_{NTC} \geq T_{T_TH}$		1		s
t_{TD}	Delay Time	$T_{NTC} < T_{T_REL}$		1		s

Typical Performance Characteristics

CLDP500-DCDC, $T_A = 25^\circ\text{C}$, $T_C = 35^\circ\text{C}$, $V_{PWR} = 72\text{V}$, balanced audio inputs, minimal dead-time

THD+N vs. Frequency (MBW = 20kHz)

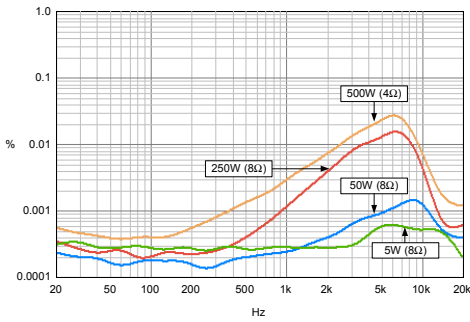

IMD 19kHz + 20kHz (10W, 4Ω)

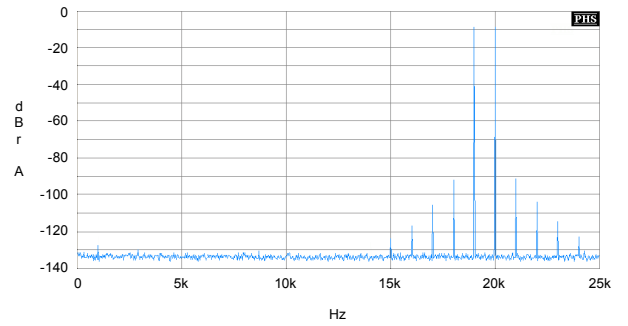

THD+N vs. Output Power (MBW = 20kHz, $Z_L = 4\Omega$)

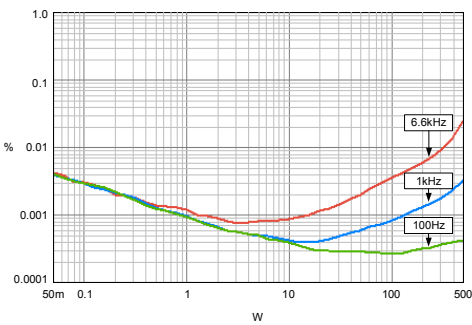

1kHz (5W, 8Ω)

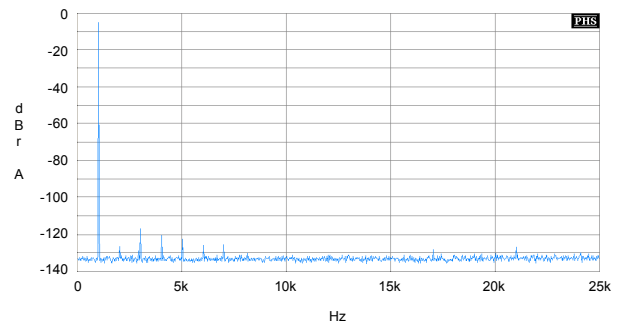

Frequency Response ($V_O = 6.33 V_{RMS}$)

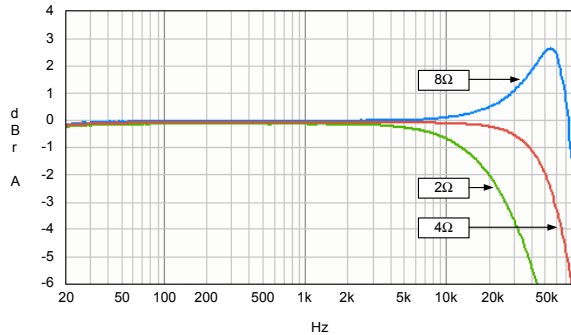

1kHz (500W, 4Ω)

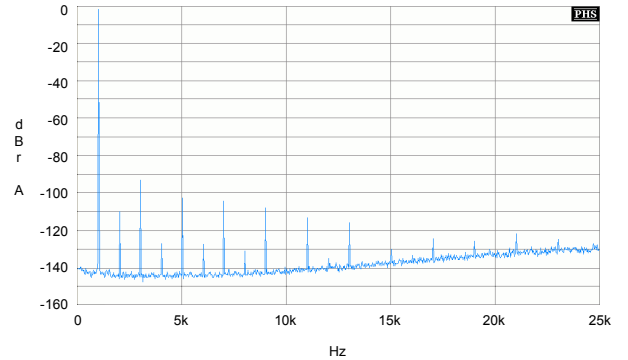

Overall Efficiency vs. Output Power (8Ω)

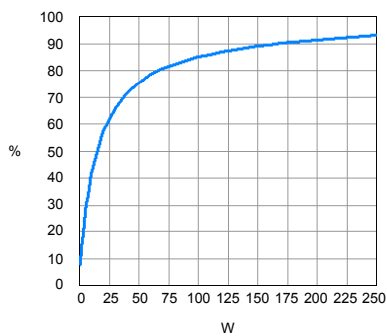

Overall Efficiency vs. Output Power (4Ω)

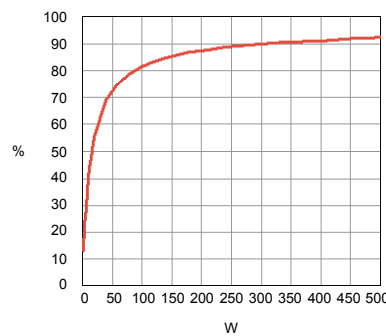

Thermal Management Outputs vs. T_{NTC}

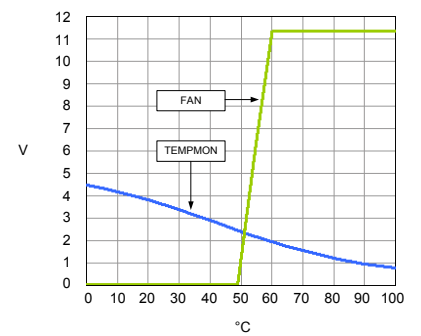

Application Information

Overview

The CLDP500 is a compact and lightweight module, ready for use in innovative audio solutions. A typical application of the module is a single channel application such as an active speaker system.

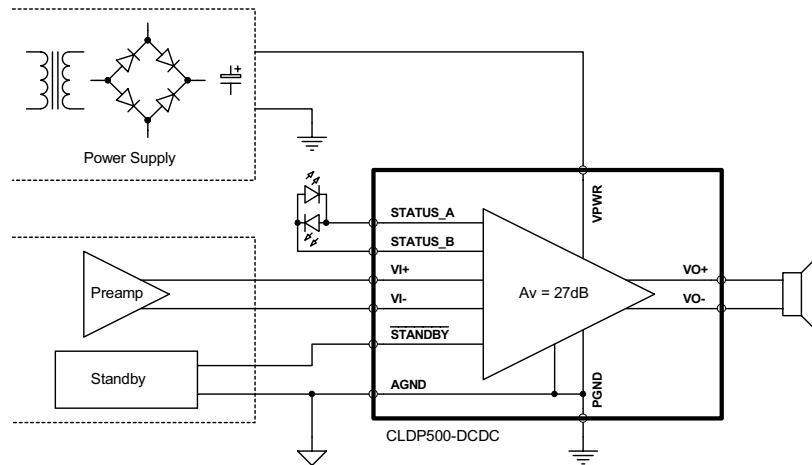

Figure 6: Application example using the CLDP500-DCDC (single supply operation)

Power Supply

The CLDP500 is available in two versions, differing in the power supply requirements.

The CLDP500-DCDC has an on-board DC/DC converter, which locally generates the required auxiliary voltages V_{CC} and V_{SS} from V_{PWR} . Therefore, the CLDP500-DCDC requires only a single supply voltage (V_{PWR}) for operation.

The CLDP500-AUXV comes without DC/DC converter and requires besides of V_{PWR} two auxiliary supply voltages from the power supply (V_{CC} and V_{SS} , +/-12V). These supplies must be well stabilized, noise and ripple will negatively affect overall system performance and voltages exceeding 13V on either line will damage the device.

Both versions of the CLDP500 have excellent power supply rejection on the main supply line (V_{PWR}), and as such there are no specific requirements for power supply stabilization. The module runs well even on an unregulated supply, linear or switch-mode, with several volts of ripple. Thanks to the full-bridge topology of the module's power stage there is no energy being pumped back towards the power supply. Therefore, power supply pumping is no concern and power supply bypassing and layout are much less critical compared to other Class-D amplifier designs.

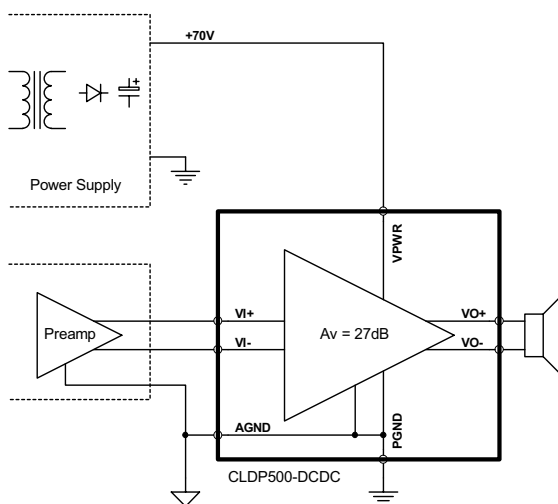

Figure 7: Powering the CLDP500-DCDC (single supply operation)

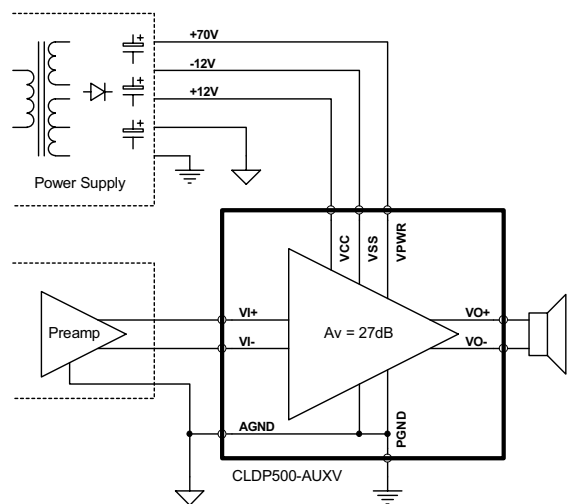

Figure 8: Powering the CLDP500-AUXV (auxiliary supply voltages required)

Audio Inputs

The balanced input section of the CLDP500 provides signal filtering and buffering. The balanced architecture helps to avoid hum and noise pick-up. If an unbalanced input is preferred this can be set by shorting VI- and AGND, however, total system performance is degraded using an unbalanced audio input.

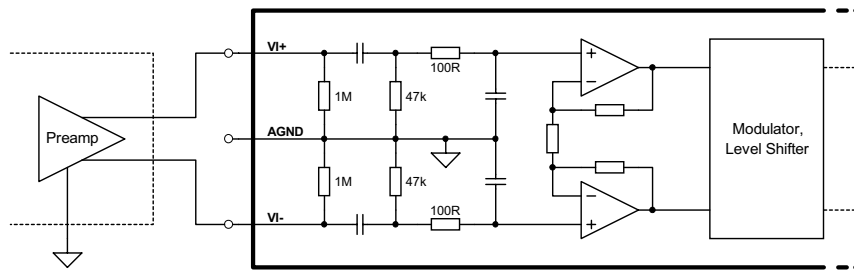

Figure 9: Audio input section

Audio Outputs

The output stage of the CLDP500 consists of the power stage in full-bridge topology and the 2nd order low-pass filter for demodulation. This leads to a balanced audio power signal on the speaker outputs VO+ and VO-.

The module is designed to have low output impedance at all frequencies and thus be almost unaffected by loading characteristics. Care should however be taken with purely capacitive loads. The module is designed to be stable with purely capacitive loads up to C_L . Higher capacitive loads may compromise stability and thus damage the module.

Caution: Both balanced speaker outputs VO+ and VO- are “hot” with a common-mode DC level equal to $V_{PWR}/2$. Always use balanced probes for monitoring and measurements. Shorting one of the terminals to ground results in an overcurrent situation.

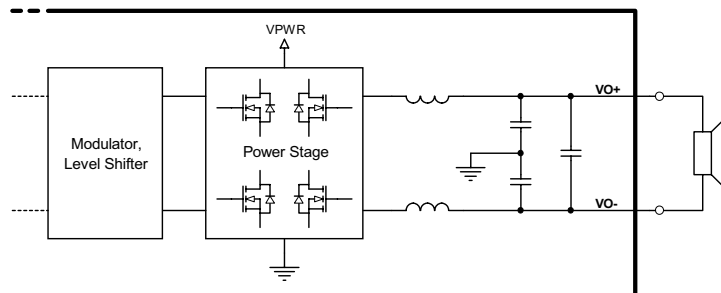

Figure 10: Audio output section

Standby Input

The standby input is active-low and internal pulled-up to +5V. Pulling the input below V_{S_L} puts the module in a low power consumption mode (standby) with pop-free muting of the speaker outputs.

Standby may be activated for example by an external switch or transistor, see examples in the figure below.

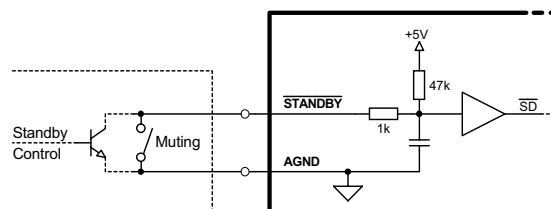

Figure 11: Standby input section

Thermal Management Outputs

The CLDP500 features active thermal management functions for demanding applications. The temperature of the module is sensed by the internal NTC thermistor placed near to the power stage (T_{NTC}). Subsequent processing of the NTC voltage provides overtemperature shutdown and outputs for temperature monitoring and fan driving.

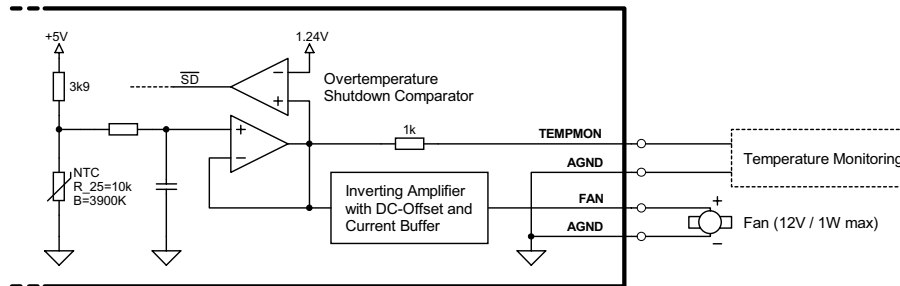

Figure 12: Thermal management section

The output TEMPMON provides the buffered voltage from the NTC thermistor and may be used for external thermal control functions.

The output FAN is capable to drive a fan for forced air cooling of the module with temperature regulated fan speed. The linear fan driver has no internal current limiter, thus the impedance of the connected fan must comply with the specified value Z_{FAN_L} to prevent damage of the driver.

For further details see the electrical specifications and the chart 'Thermal Management Outputs vs. T_{NTC} ' in the section 'Typical Performance Characteristics'.

Status Outputs

The status outputs indicate the actual operation mode of the CLDP500. Both outputs provide logic-level signals, see the electrical specifications and the table below for details.

Operation Mode	STATUS_A	STATUS_B
Active	Low	High
Standby	High	Low

Table 1: Logical states of the status outputs

The status outputs may be used by an external controller to monitor the actual operation mode of the CLDP500. Alternatively, the outputs may drive LEDs, optional in conjunction with the internal resistors on the pins R_PUP and R_PDN. Various connection schemes are possible, see examples in the figure below.

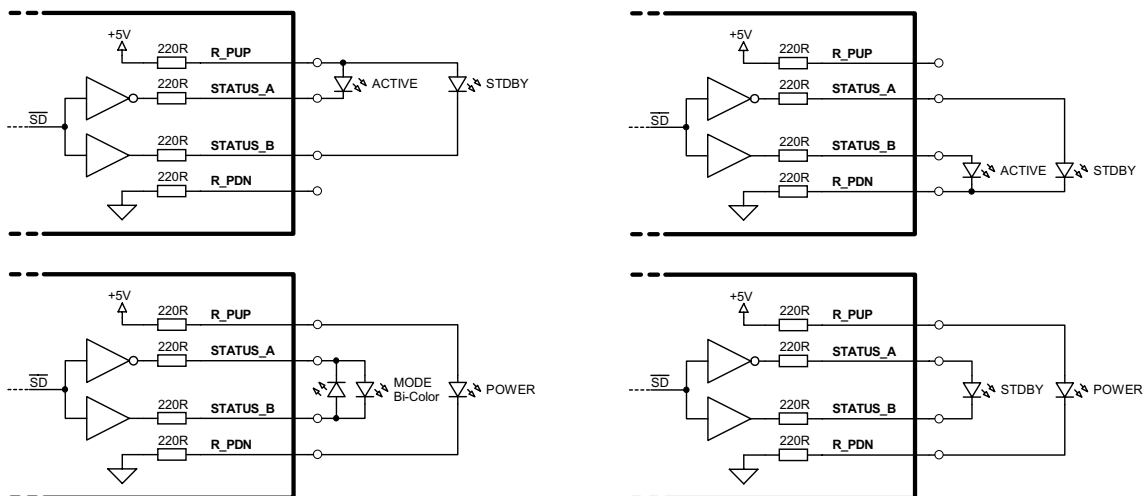

Figure 13: LED connection examples

Adjustable Dead-Time

The CLDP500 features a proprietary technique to set the dead-time of the power stage, which allows tuning the module with respect to minimizing THD or power consumption.

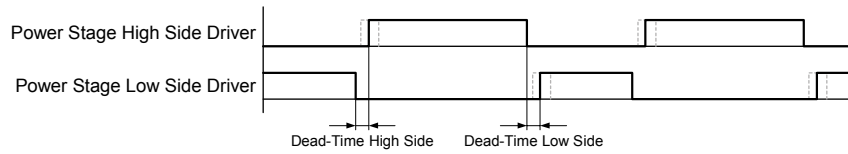

Figure 14: Dead-time timing diagram

Setting of dead-time is achieved by adjusting the trimming potentiometer located at the center of the module.

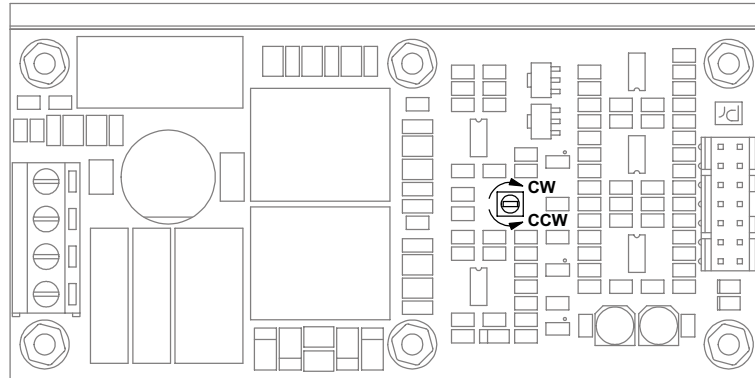

Figure 15: Trimming potentiometer to set dead-time

Reducing dead-time results in lower THD and higher power consumption (increase of I_{VPWR_Q}) and vice versa. Thus, to achieve best audio performance turn the potentiometer counterclockwise to the left stop (factory default), to achieve minimal power consumption turn the potentiometer clockwise to the right stop.

Trimmer Turning Direction	Dead-Time	THD	Power Consumption
CCW	Decreased	Decreased	Increased
CW	Increased	Increased	Decreased

Table 2: Impact of dead-time setting on THD and power consumption

On-Board LEDs

The CLDP500 has two LEDs on-board, indicating “Power On” (LED A) and “Active Mode” (LED B).

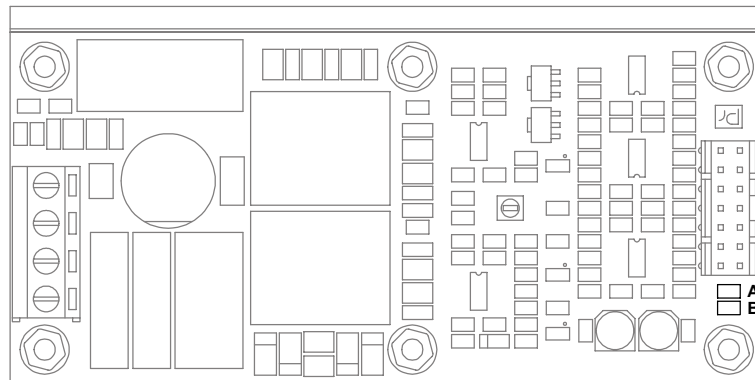

Figure 16: On-Board LEDs

Operation

Protection Circuits

The CLDP500 has a number of internal protection circuits to safeguard the power stage when a fault condition is detected.

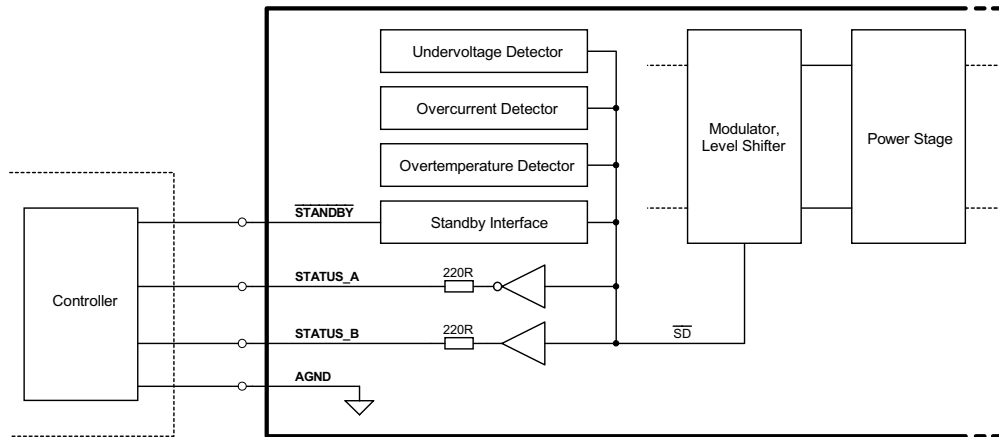

Figure 17: Internal protection circuits

Operation Modes

The module will shutdown the power stage with a short propagation delay (t_{xPD}) and enter standby mode if one or several of the following conditions arise:

- Undervoltage Detector
One or several supply voltages (V_{PWR} , V_{CC} , V_{SS} , internal +5V) is below the minimum acceptable level
- Overcurrent Detector
The load current exceeds the maximum acceptable level
- Overtemperature Detector
The module temperature exceeds the maximum acceptable level
- Standby Input
The standby input is pulled low

Once the cause for shutdown is removed, the module waits for a timed delay (t_{xD}) to ensure stable conditions before enabling the power stage and entering active mode. See the electrical specifications for details concerning threshold levels and delay times.

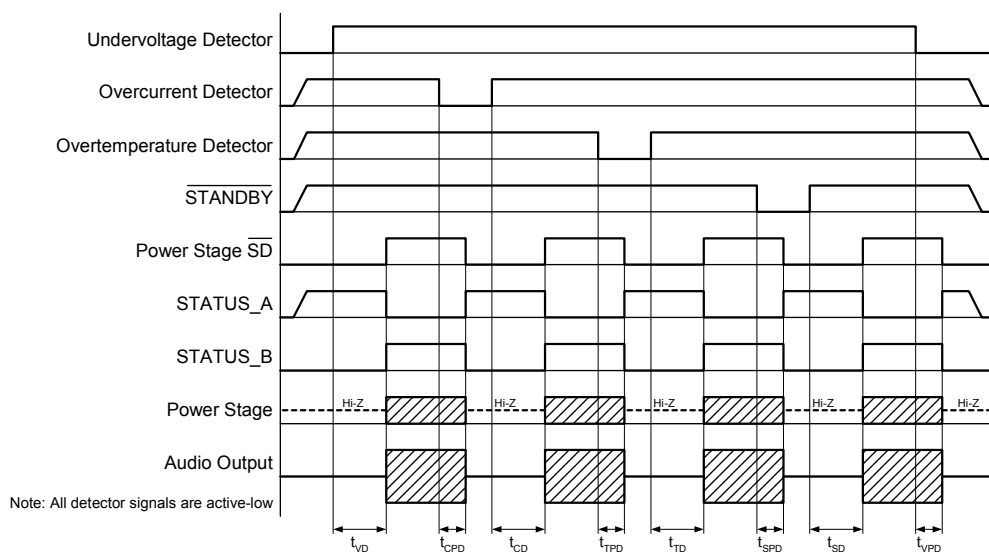

Figure 18: Operational timing diagram

Thermal Design Considerations

Cooling

The CLDP500 is based on very efficient Class-D technology providing high overall efficiency characteristics at all levels of operation. For further information see the charts 'Overall Efficiency vs. Output Power' in the section 'Typical Performance Characteristics'.

Although the high efficiency of the module, additional cooling is essential for reliable operation. The required heat sink for the module can be designed using normal thermal design considerations. Please keep in mind that the module relies on both the heat sink and the ambient air for cooling and so it must be ensured that neither T_C nor T_A is exceeded during normal operation. However, mounting the module to an aluminum backplane or enclosure is normally sufficient to ensure trouble-free operation even under continuous loading.

The internal overtemperature protection of the CLDP500 will shutdown the module before overheating and the output TEMPMON may be used for external thermal control functions. The output FAN may drive a fan to achieve forced air cooling of the module with temperature regulated fan speed. For further details see section 'Thermal Management Outputs'.

Mounting

The aluminum mounting bracket of the CLDP500 has three holes (diameter 3.3mm) and four threads (M3) for mounting the module onto a heat sink. When using the M3 threads of the module for mounting, the length of the used screws must be selected such that the maximum penetration is below 4mm.

Applying thermally conductive material such as grease or a thermal pad between the module and the heat sink is highly recommended.

There is no strict restriction on the mounting direction of the module, but convection must be ensured by providing enough airflow at the components of the module.

Ordering Information

CLDP500-DCDC Audio amplifier module with on-board DC/DC converter (single supply operation)

CLDP500-AUXV Audio amplifier module without DC/DC converter (auxiliary supply voltages required)

Physical Dimensions

All dimensions in mm, tolerance is $\pm 0.2\text{mm}$ unless otherwise noted

